

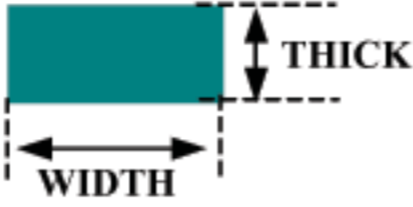



# TECHNICAL DATA SHEET

## PULTRUSION PROFILES

PROFILE	PICTURE	SIZES																								
<b>RECTANGULAR FLATS</b>		<ul style="list-style-type: none"> <li>➤ MAXIMUM AREA OF RECTANGULAR FLAT UPTO <b>2250</b> SQUARE MM</li> <li>➤ THICKNESS FROM <b>3MM</b> TO <b>40MM</b></li> </ul>																								
<b>SQUARE TUBE</b>		<table border="1" style="margin: auto;"> <thead> <tr> <th style="width: 50%;">A</th> <th style="width: 50%;">B(DIA)</th> </tr> </thead> <tbody> <tr> <td style="text-align: center;">40</td> <td style="text-align: center;">20</td> </tr> </tbody> </table>	A	B(DIA)	40	20																				
A	B(DIA)																									
40	20																									
<b>RODS</b>		<ul style="list-style-type: none"> <li>➤ RODS FROM DIA 6 - 50 MM</li> </ul>																								
<b>CHANNELS</b>		<table border="1" style="margin: auto;"> <thead> <tr> <th style="width: 33%;">A</th> <th style="width: 33%;">B</th> <th style="width: 33%;">C</th> </tr> </thead> <tbody> <tr><td style="text-align: center;">40</td><td style="text-align: center;">40</td><td style="text-align: center;">3</td></tr> <tr><td style="text-align: center;">40</td><td style="text-align: center;">40</td><td style="text-align: center;">4</td></tr> <tr><td style="text-align: center;">60</td><td style="text-align: center;">35</td><td style="text-align: center;">6</td></tr> <tr><td style="text-align: center;">75</td><td style="text-align: center;">30</td><td style="text-align: center;">4</td></tr> <tr><td style="text-align: center;">100</td><td style="text-align: center;">35</td><td style="text-align: center;">4</td></tr> <tr><td style="text-align: center;">100</td><td style="text-align: center;">50</td><td style="text-align: center;">6</td></tr> <tr><td style="text-align: center;">150</td><td style="text-align: center;">50</td><td style="text-align: center;">5</td></tr> </tbody> </table>	A	B	C	40	40	3	40	40	4	60	35	6	75	30	4	100	35	4	100	50	6	150	50	5
A	B	C																								
40	40	3																								
40	40	4																								
60	35	6																								
75	30	4																								
100	35	4																								
100	50	6																								
150	50	5																								
<b>RECTANGULAR TUBES</b>		<table border="1" style="margin: auto;"> <thead> <tr> <th style="width: 33%;">A</th> <th style="width: 33%;">B</th> <th style="width: 33%;">C</th> </tr> </thead> <tbody> <tr> <td style="text-align: center;">45</td> <td style="text-align: center;">22</td> <td style="text-align: center;">3</td> </tr> </tbody> </table>	A	B	C	45	22	3																		
A	B	C																								
45	22	3																								
<b>I SECTION</b>		<table border="1" style="margin: auto;"> <thead> <tr> <th style="width: 33%;">A</th> <th style="width: 33%;">B</th> <th style="width: 33%;">C</th> </tr> </thead> <tbody> <tr> <td style="text-align: center;">15</td> <td style="text-align: center;">30</td> <td style="text-align: center;">5</td> </tr> </tbody> </table>	A	B	C	15	30	5																		
A	B	C																								
15	30	5																								
<b>L ANGLE</b>		<table border="1" style="margin: auto;"> <thead> <tr> <th style="width: 50%;">A</th> <th style="width: 50%;">B</th> </tr> </thead> <tbody> <tr> <td style="text-align: center;">50</td> <td style="text-align: center;">4</td> </tr> <tr> <td style="text-align: center;">50</td> <td style="text-align: center;">6</td> </tr> <tr> <td style="text-align: center;">62</td> <td style="text-align: center;">6</td> </tr> </tbody> </table>	A	B	50	4	50	6	62	6																
A	B																									
50	4																									
50	6																									
62	6																									

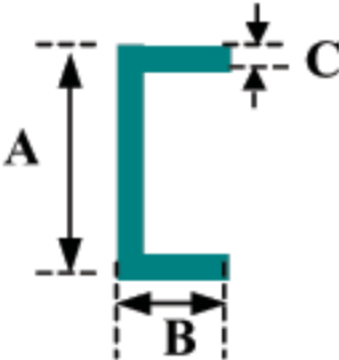
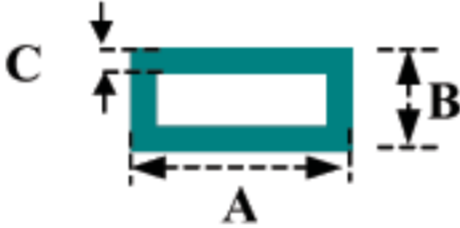
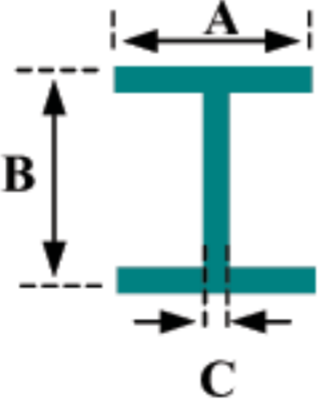
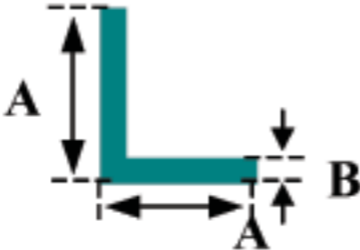
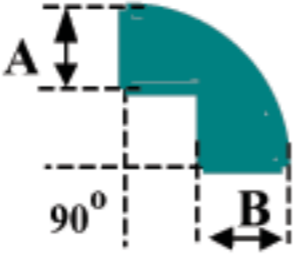
# TECHNICAL DATA SHEET

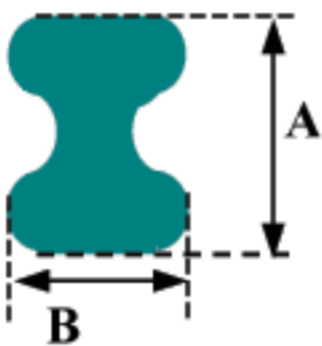
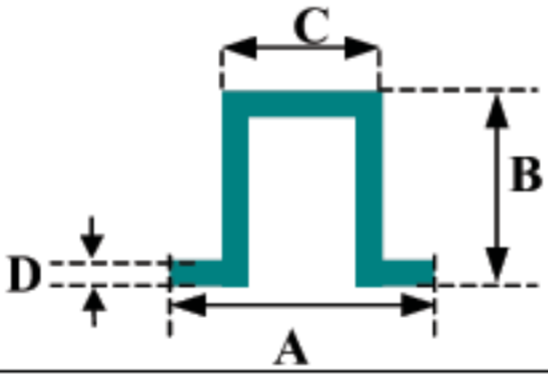
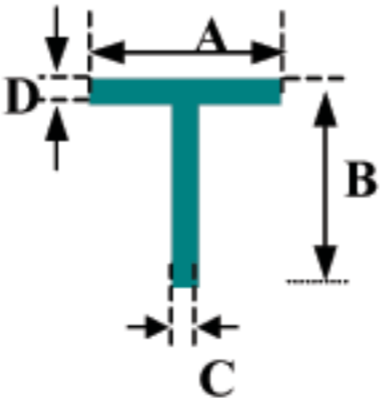
<b>CORNER PIECE</b>		<table border="1" style="margin: auto;"> <thead> <tr> <th style="width: 50%;">A</th> <th style="width: 50%;">C</th> </tr> </thead> <tbody> <tr><td>6</td><td>6</td></tr> <tr><td>8</td><td>8</td></tr> <tr><td>8</td><td>13</td></tr> <tr><td>13</td><td>13</td></tr> </tbody> </table>	A	C	6	6	8	8	8	13	13	13																								
A	C																																			
6	6																																			
8	8																																			
8	13																																			
13	13																																			
<b>TUBES</b>		<table border="1" style="margin: auto;"> <thead> <tr> <th style="width: 50%;">ID</th> <th style="width: 50%;">OD</th> </tr> </thead> <tbody> <tr><td>10</td><td>15.8</td></tr> <tr><td>14</td><td>21</td></tr> <tr><td>15</td><td>22</td></tr> <tr><td>16.6</td><td>22</td></tr> <tr><td>17.5</td><td>22</td></tr> <tr><td>20</td><td>24</td></tr> <tr><td>22</td><td>27</td></tr> <tr><td>26</td><td>32</td></tr> <tr><td>28</td><td>32</td></tr> <tr><td>28</td><td>33</td></tr> <tr><td>32</td><td>39</td></tr> <tr><td>35</td><td>41</td></tr> <tr><td>44.4</td><td>52</td></tr> <tr><td>52</td><td>60</td></tr> <tr><td>56</td><td>60</td></tr> <tr><td>67.5</td><td>73.5</td></tr> </tbody> </table>	ID	OD	10	15.8	14	21	15	22	16.6	22	17.5	22	20	24	22	27	26	32	28	32	28	33	32	39	35	41	44.4	52	52	60	56	60	67.5	73.5
ID	OD																																			
10	15.8																																			
14	21																																			
15	22																																			
16.6	22																																			
17.5	22																																			
20	24																																			
22	27																																			
26	32																																			
28	32																																			
28	33																																			
32	39																																			
35	41																																			
44.4	52																																			
52	60																																			
56	60																																			
67.5	73.5																																			
<b>DOG BONES</b>		<table border="1" style="margin: auto;"> <thead> <tr> <th style="width: 50%;">A</th> <th style="width: 50%;">B</th> </tr> </thead> <tbody> <tr><td>10</td><td>8</td></tr> <tr><td>12</td><td>10</td></tr> <tr><td>13</td><td>10</td></tr> <tr><td>16</td><td>10</td></tr> <tr><td>19</td><td>12</td></tr> <tr><td>25</td><td>16</td></tr> </tbody> </table>	A	B	10	8	12	10	13	10	16	10	19	12	25	16																				
A	B																																			
10	8																																			
12	10																																			
13	10																																			
16	10																																			
19	12																																			
25	16																																			
<b>HAT PROFILES</b>		<table border="1" style="margin: auto;"> <thead> <tr> <th style="width: 25%;">A</th> <th style="width: 25%;">B</th> <th style="width: 25%;">C</th> <th style="width: 25%;">D</th> </tr> </thead> <tbody> <tr><td>24.5</td><td>14</td><td>14.7</td><td>2.7</td></tr> <tr><td>24.5</td><td>18</td><td>14.7</td><td>2.7</td></tr> <tr><td>24.5</td><td>24</td><td>14.7</td><td>2.7</td></tr> </tbody> </table>	A	B	C	D	24.5	14	14.7	2.7	24.5	18	14.7	2.7	24.5	24	14.7	2.7																		
A	B	C	D																																	
24.5	14	14.7	2.7																																	
24.5	18	14.7	2.7																																	
24.5	24	14.7	2.7																																	
<b>T SECTION</b>		<table border="1" style="margin: auto;"> <thead> <tr> <th style="width: 25%;">A</th> <th style="width: 25%;">B</th> <th style="width: 25%;">C</th> <th style="width: 25%;">D</th> </tr> </thead> <tbody> <tr><td>15</td><td>30</td><td>5</td><td>5</td></tr> <tr><td>40</td><td>50</td><td>15</td><td>10.6</td></tr> </tbody> </table>	A	B	C	D	15	30	5	5	40	50	15	10.6																						
A	B	C	D																																	
15	30	5	5																																	
40	50	15	10.6																																	

# TECHNICAL DATA SHEET

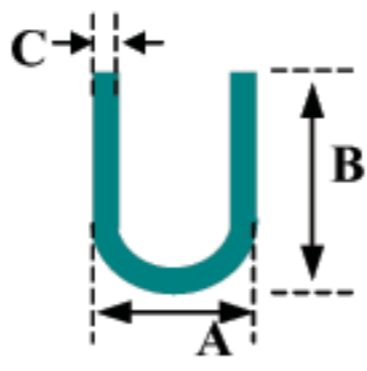
<b>U SECTION</b>		<b>A</b>	<b>B</b>	<b>C</b>
		20	38	5

**Note:**

1. Custom made profiles for the shapes required can also be provided
2. All measurements of length are in mm
3. All measurements of weight are in kg